



CITEL

SURGE PROTECTION

for

photovoltaic systems

EFFICIENT PROTECTION OF YOUR PHOTOVOLTAIC SYSTEM

As a specialist for lightning and surge protection, the safety of people and systems is a basic need for us. Therefore, for more than 80 years we have been dealing with the question of how we can improve the safety and durability of your plants and thus also contribute to their economic efficiency. Our team has many years of experience and comprehensive knowledge of the special challenges that a DC application up to 1,500 V offers.

CITEL has developed the patented VG technology on the basis of continuous research and expertise, as well as on the basis of the ever-increasing normative requirements for protective measures. This unique hybrid technology of high-power varistor

(MOV) and gas-filled spark gap (GSG) stands for optimum robustness and reliability while ensuring the highest possible level of protection.

This technology can also be found in our lightning and surge protective devices (SPDs) to protect your photovoltaic system. In order to offer planners, installers and operators of photovoltaic systems a comprehensive protection concept, our portfolio is rounded off by special protection devices for sensor, data and communication cables. It makes no difference whether it is a system for your single-family home, a commercial building or a photovoltaic power plant.

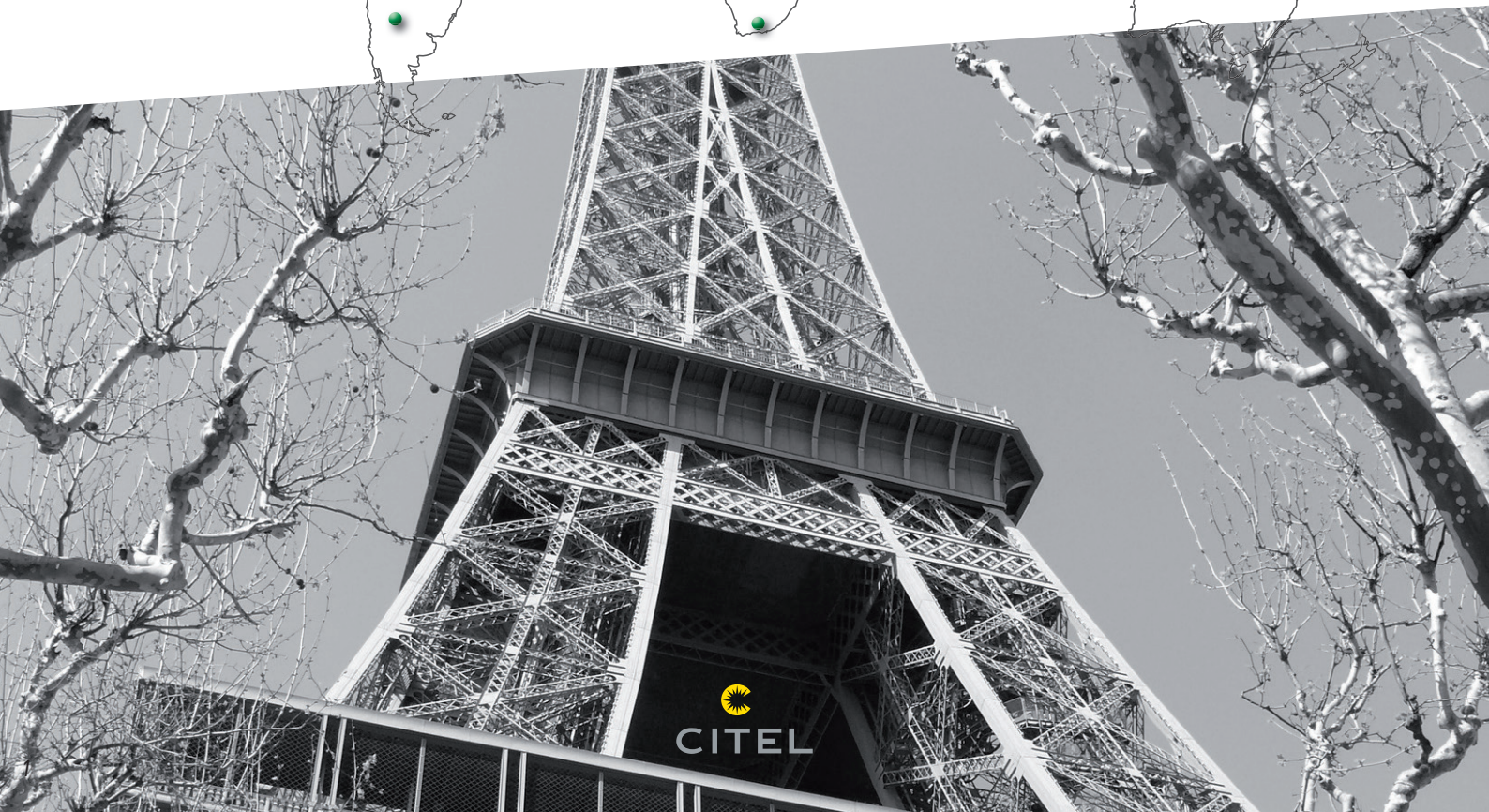



CITEL PRODUCTS ARE EASY TO PLAN, QUICK TO INSTALL & HELP SAVE MONEY.

Advantages for the planner and installer

- ✓ Comprehensive portfolio for all common applications
- ✓ Innovative system through continuous development
- ✓ Easy coordination with existing protective devices

Even after planning and installation, CITEL's protective devices have many advantages for the investor and operator of the plant.

Advantages for the operator

- ✓ Optimum protection through the latest technology, low protection levels and high discharge capacity
- ✓ Long lifetime due to high-quality equipment from our own production and strict quality assurance
- ✓ Perfectly matched devices that provide a complete surge protection system.

Above all, this means trouble-free operation of the plant and thus a high degree of economic efficiency. In the following we have composed the regulations and requirements for the most common applications. If you have any questions, please do not hesitate to contact us.

THE REQUIREMENTS OF THE MARKET

Due to the constantly growing share of photovoltaic systems for energy generation in Germany, Europe and worldwide, the question of system and yield security is becoming increasingly important. In the planning phase of a photovoltaic system, attention should therefore be paid to the required lightning and surge protection concept. In this way you'll avoid unnecessary costs for retrofitting. Special attention should be paid to the sensor technology and the communication lines, since overvoltages can also couple in this way, which can cause serious damage to the system, especially to the inverter. It should be clarified with the insurer which requirements must be met. The basis for this is the new standard DIN VDE 0100-712, which deals specifically with the installation of photovoltaic power supply systems. A good overview for special structural facilities, which also include photovoltaic systems, is provided by the bulletin "VdS 2010", published by the "Verband der Sachversicherer e.V." (VdS, Association of Insurers). Here, lightning and surge protection of lightning protection class III is required for photovoltaic systems with an output of 10 kW or more on buildings, and internal surge protection is required as minimum protection for ground-mounted systems. If a photovoltaic system is installed on a public building, the state building regulations must be taken into account in addition to the applicable standards IEC 60364-4-44, IEC 60364-5-53 and

EN 62305 (DIN VDE 0185-305). Numerous sensitive public buildings such as hospitals must therefore be equipped with a lightning protection system and protected with an external and internal lightning protection system in accordance with EN 62305. The photovoltaic system is part of the electrical installation and must therefore also be included in the protection concept. Even for systems without external lightning protection, IEC 60364-4-44 mostly requires surge protection. In many national versions of this rule this applies in particular to individuals, e.g. in residential buildings and offices, if equipment of overvoltage category I or II is installed, which is always assumed in practice. CLC/TS 50539-12 and DIN VDE 0100-712 also describe a similar situation, quoting from chapter 4.5 of VDE V 0675-39-12: "As long as the risk calculation according to VDE 0185-305-2 does not provide any other statement, the installation of SPDs on the DC and AC side of photovoltaic systems is mandatory". DIN VDE 0100-712 describes in the normative appendix ZB to chapter 712.443.101: "If protection against transient overvoltages is required by DIN VDE 0100-443, section 443, such protection must also be applied on the DC side of the photovoltaic system".

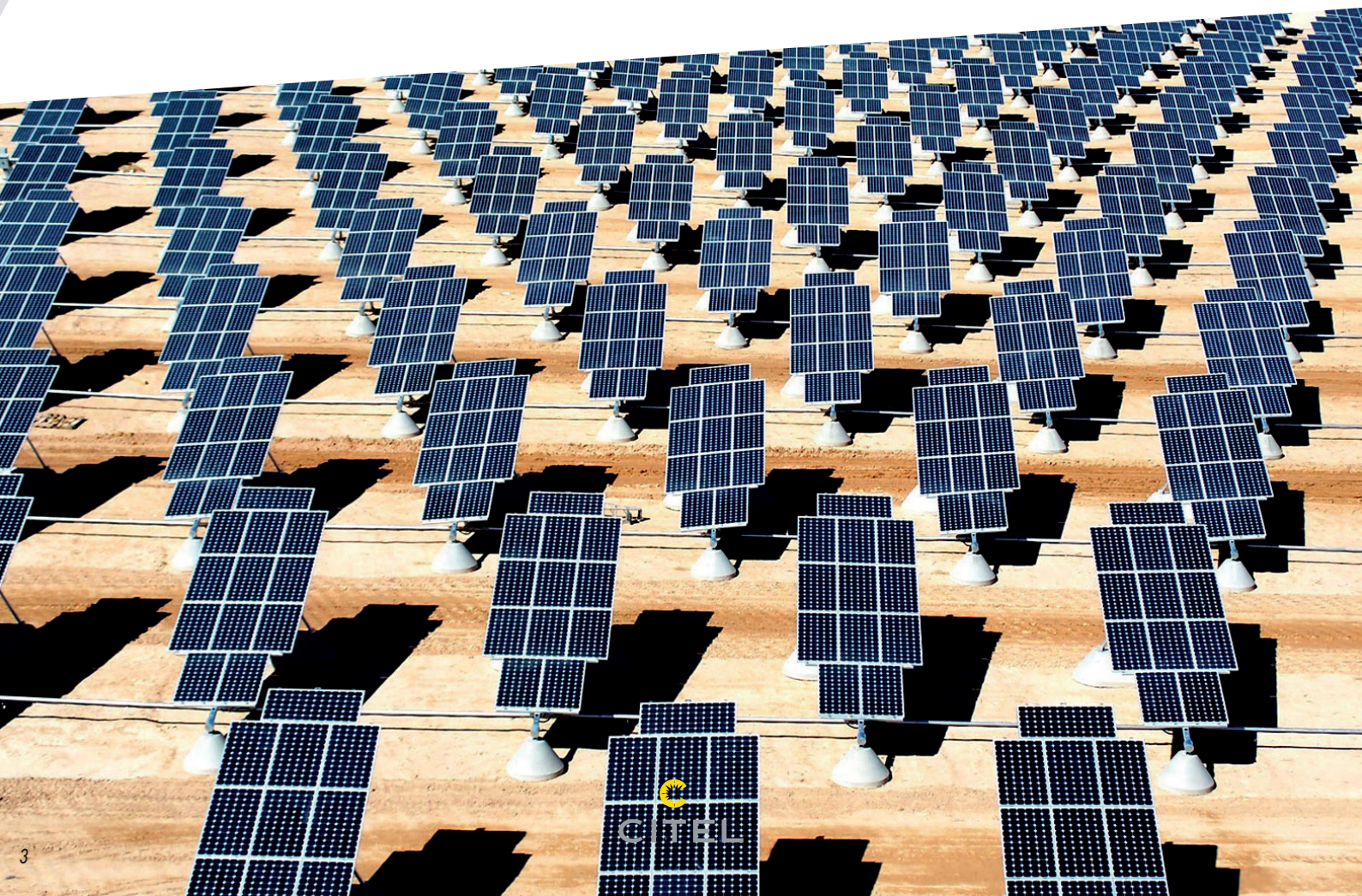

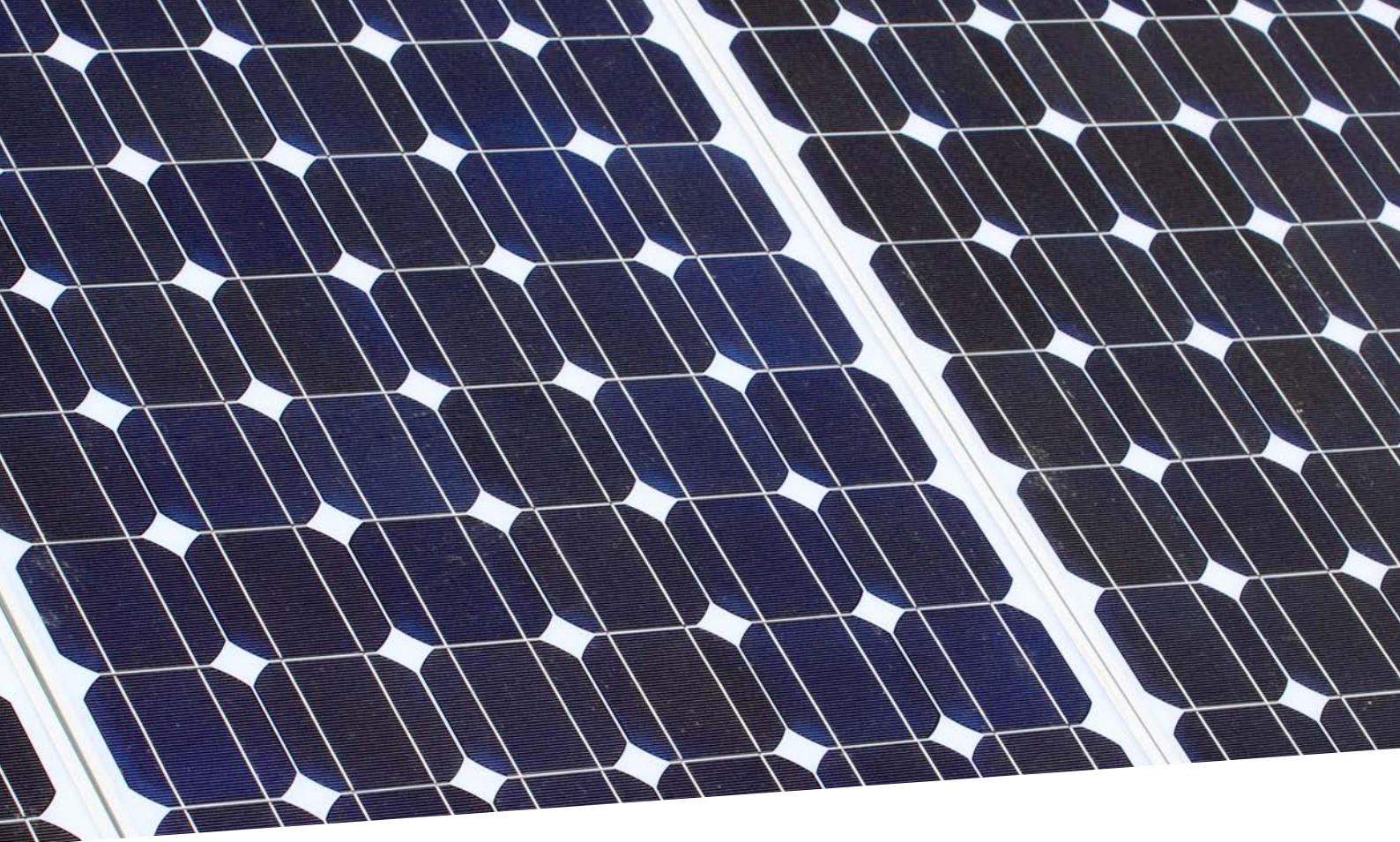

The selection: Protection of the DC side

When selecting surge protection devices in photovoltaic systems, the SPDs must be designed for the maximum open circuit voltage of the photovoltaic generator. In contrast to the "normal" (230V/50Hz) low-voltage network, this is a direct voltage that can reach up to 1500V. Furthermore, it must be considered if an external lightning protection system is available. According to EN 62305, sufficiently large separation distances between the photovoltaic and lightning protection system must be calculated and maintained. In practice these are often between 0.5 and 1 m. If the separation distance cannot be maintained, a lightning current capable connection must be established between the external lightning protection system and the module frame or rack. In this case partial lightning currents are coupled into the DC side and an SPD type 1 or even better an SPD type 1+2 (DS60VGPPV) surge protector must be installed. If the separation distance is maintained or there is no external lightning protection system, only coupled overvoltages are expected on the DC side and an SPD type 2 (DS50VGPVS) provides the necessary protection. Lightning strikes or overvoltages on the DC side can also endanger all other electrical systems in a plant. Therefore, in addition to the AC and DC sides, the sensor, data and communication lines should always be included in the protection system.

The selection: Protection of the AC side

Reliable protection of the AC side, even in photovoltaic systems, must always be provided in accordance with IEC 60364-4-44. A type 1+2+3 surge protector directly upstream or downstream of the meter provides a very good protection level and maximum load capacity by combining all three protection levels. As an alternative to conventional DIN rail mounting, CITEL also offers a variant for simple busbar mounting in the pre-meter area.

Protection of the sensor, data and communication lines

All sensor, data and communication lines should also be protected against coupled overvoltages. Today's inverters nearly always have interfaces for connecting irradiation, (module) temperature or a variety of other sensors, as well as connection options to monitoring portals (e.g. Ethernet, RS485 or others). Adapted to the specific interface (data rate, voltage, frequency, etc.) CITEL offers a wide range of solutions.

PHOTOVOLTAIC SYSTEM ON YOUR SINGLE-FAMILY HOME

CITEL offers complete protection for all areas

In practice, a distinction is made between houses with or without external lightning protection. If no external lightning protection is required for a building, it can be assumed that there is no increased risk of a direct lightning strike. The surge protection on the DC side of the photovoltaic system must therefore only be installed against indirect coupled overvoltages. In this case, a type 2 SPD (DS50VGPVS) must be provided on both the photovoltaic generator and the inverter. If the cable lengths between generator and inverter are negligible (<10m), then only one of the two surge protection devices is necessary. The string lines of the generator cabling may potentially form a large induction loop if there are inductively coupling surge events such as near strikes of lightning in a radius of about 2 km. In order to achieve an increased level of safety here that exceeds the normative requirements, CITEL recommends using a type 1+2 surge protector (DS50VGPVS/12KT1) even in buildings without external lightning protection. On the AC side, type 1+2+3 surge protectors (ZPAC or DAC1-13VGS) in the meter cabinet provide optimum protection. This protects the AC input of the inverter and the electrical installation of the building equally. For houses with external lightning protection, which is usually not mandatory, further regulations apply, about which we will be happy to provide you with detailed information if required.



Lightning protection equipotential bonding (DC)

Type 1+2 surge protectors protect against overvoltages and also against (partial) lightning currents and safely discharge them.

Complete protection can only be achieved in conjunction with external lightning protection.



Lightning protection equipotential bonding (AC)

Type 1+2+3 surge protectors are ideally installed at the building entrance and protect against lightning currents and switching overvoltages.



The unique CITEL VG Technology offers users the following advantages:

- ✓ No leakage currents, no component aging, minimum maintenance
- ✓ Robust product design, long lifetime, 10 year operational guarantee
- ✓ Leakage-free and follow-current-free, no losses, no follow-up costs

Surge protection (DC)

Type 2 surge protection devices protect against overvoltages caused by field coupling or switching operations.



INDUSTRIAL, COMMERCIAL AND PUBLIC BUILDINGS

CITEL solutions in consideration of the separation distance

CITEL also offers very good lightning and surge protection solutions for systems with external lightning protection. First of all, the necessary separation distance "s" between the photovoltaic system and the external lightning protection system must be calculated according to EN 62305-3 and ideally maintained. The necessary separation distance is not only limited to the modules and their substructure, but also includes the installation of the string lines.

Protection while maintaining the separation distance

If an external lightning protection system is available, the photovoltaic system should be constructed isolated and should be completely within the protection area of the lightning protection system. If the calculated separation distance is maintained, only indirect coupling overvoltages are to be expected. To protect the generator and inverter, a type 2 SPD is sufficient according to the standards.

Protection in case of going below the separation distance

If the separation distance falls below the minimum required, the photovoltaic system must be included in the external lightning protection system by lightning current capable connections. This avoids dangerous flashovers and the associated fire hazard in the event of direct lightning strikes. Since partial lightning currents are now to be expected on the DC lines, the generator and inverter must be protected with type 1 or type 1+2 surge protectors (DS60VGPV). Here too, one of the two protectors may be omitted for cable lengths of <10 m.



AC side

Since commercial and industrial buildings are usually properties with high material assets and public institutions are buildings with sensitive information and data material, complete protection is particularly important here. A surge protector T1+2+3, such as the DS250VG or the DUT250VG, guarantees the best possible protection of the AC side by a low protection level of <1500V, combined with a total lightning current discharge capability of 100 kA (25kA/pole).

Separation distance "s"

- Calculation of separation distance "s" according to EN 62305-3
- Compliance with "s" → Type 2 SPD (DC)
- Failure to comply with "s" → Type 1+2 SPD (DC)

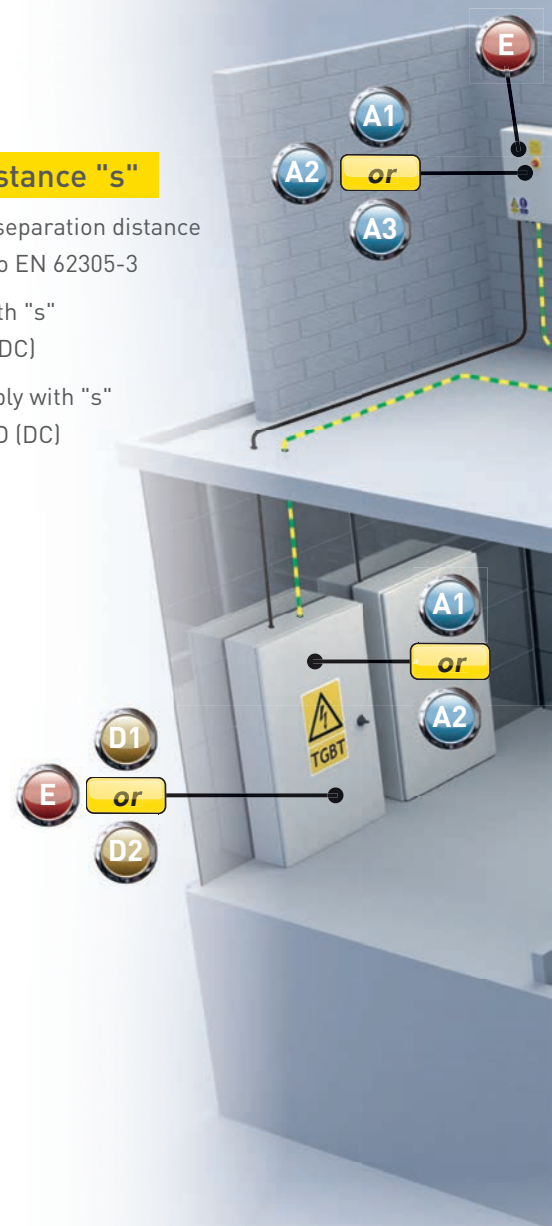



The unique CITEL VG Technology offers users the following advantages:

- ✓ No leakage currents, no component aging, minimum maintenance
- ✓ Robust product design, long lifetime, 10 year operational guarantee
- ✓ Leakage-free and follow-current-free, no losses, no follow-up costs



EFFICIENT PROTECTION OF GROUND-MOUNTED PHOTOVOLTAIC POWER PLANTS

How do I protect my photovoltaic power plant correctly against overvoltages?

Photovoltaic power plants today are equipped with more and more technology. In addition to monitoring systems for pure performance monitoring, this includes, above all, an increasing number of sensors for recording and evaluating environmental conditions such as ambient temperature, module temperature, irradiation and wind speed. The currents of the individual strings are also often precisely recorded. In addition, tracking systems are sometimes used to automatically track the modules according to the position of the sun. The protection of all these systems is particularly important here. When creating the protection concept, these data and control lines should therefore be consistently included.

Free field power plants have a larger spatial extension and thus a higher lightning risk during thunderstorms than compact rooftop installations. The EN 61643-32 takes this into account by requiring the use of type 1 surge protectors on the DC side of open space systems.

CITEL recommends:

Surge protectors with VG technology of type 1+2 on the DC side and type 1+2+3 on the AC side offer the best possible protection for your investment against all types of surge events.



Earthing and equipotential bonding

All metallic elements must be electrically connected to each other to avoid potential differences.

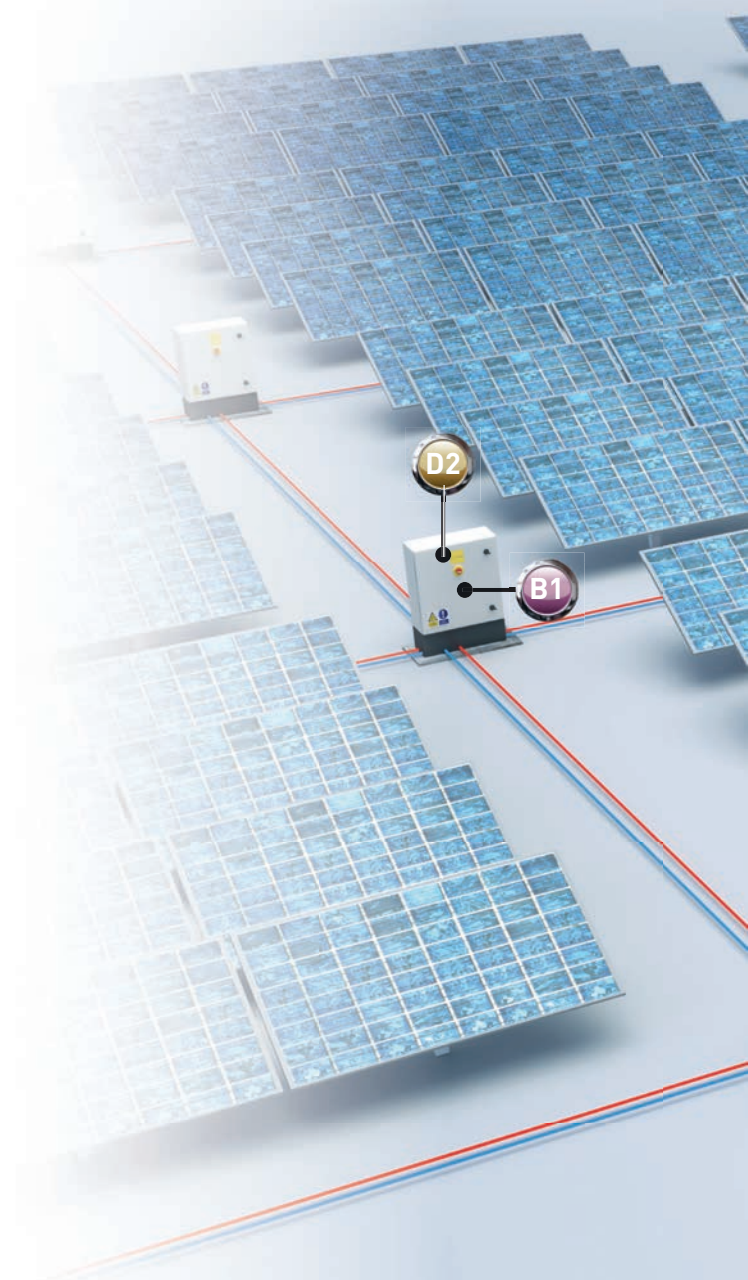



The unique CITEL VG Technology offers users the following advantages:

- ✓ No leakage currents, no component aging, minimum maintenance
- ✓ Robust product design, long lifetime, 10 year operational guarantee
- ✓ Leakage-free and follow-current-free, no losses, no follow-up costs

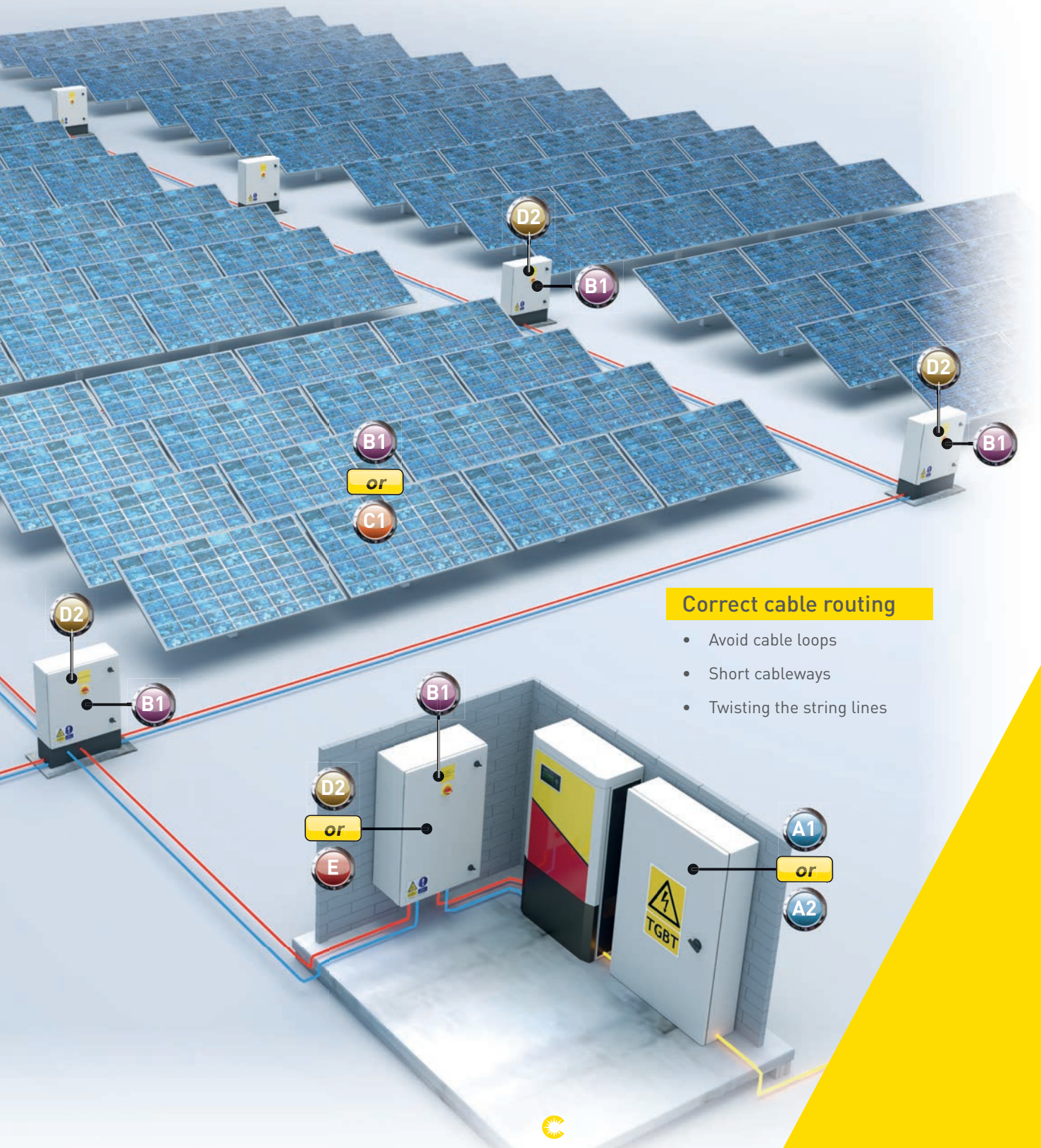

Correct cable routing

- Avoid cable loops
- Short cableways
- Twisting the string lines

INNOVATIONS: STATE OF THE ART / STANDARDS

For the professional installation of a lightning and surge protection concept for photovoltaic systems, only the pre-standard CLC/TS 50539-12 (VDE V 0675-39-12) was available to the user in addition to Supplement 5 of the lightning protection standard EN 62305-3 and the information provided by the "Verband der Sachversicherer e.V." in the VdS bulletin 2010.

Since September 2017, the new application standard IEC 61643-32 ED1 has been published at international level, which is implemented nationally in the VDE 0675-6-32 draft. The new DIN VDE 0100-712 now also contains additional requirements for protecting systems against overvoltages.

The new IEC 61643-32 essentially builds on the already known CLC/TS 50539-12.

Both standards cover the selection and application principles of surge protection devices for use in photovoltaic installations. This involves measures against surge damage to increase the safety and availability of the system, buildings with and without external lightning protection, the treatment of the separation distance and the use of surge protection devices in free field systems. Furthermore, specifications are given for the selection and installation of surge protection devices on the DC and AC side. The new IEC 61643-32 also requires the use of SPDs for data and communication lines.

The IEC 61643-32 states:

"The installation of SPDs on the DC and AC sides of a PV installation is mandatory unless indicated otherwise by a risk assessment".

It also states: "When SPDs are installed to protect the PV installation, it is necessary also to protect any telecommunication and signalling circuits which are part of the PV system".

The obligation to protect photovoltaic systems against overvoltages also results from the new DIN VDE 0100-712.























This refers to Supplement 5 of the lightning protection standard VDE 0185-305-3 (EN 62305-3): "The selection and installation of surge protection devices (SPDs) in PV systems must be carried out in accordance with DIN EN 62305-3 Supplement 5 (VDE 0185-305-3 Supplement 5)". In turn, Supplement 5 contains the requirement: "The necessity of surge protection measures on the AC side of the PV power supply system is determined in accordance with DIN VDE 0100-443". As is well known, this in turn makes the use of SPDs mandatory in every installation. Furthermore, DIN VDE 0100-712 states: "If protection against transient overvoltages is required by DIN VDE 0100-443, section 443, such protection must also be applied on the DC side of the photovoltaic system".

For PV systems on or near buildings, DIN VDE 0100-712 also provides assistance for the correct selection of protective devices (minimum requirement) in the informative appendix C:





MINIMUM REQUIREMENTS

Situation	AC main distribution	Inverter		Photovoltaic generator field
		AC side	DC side	
Building without external lightning protection	SPD type 2 	SPD type 2 	SPD type 2  	SPD type 2  
Building with external lightning protection, separation distance maintained	SPD type 1  	SPD type 2 	SPD type 2  	SPD type 2  
Building with external lightning protection, separation distance not maintained	SPD type 1  	SPD type 1  	SPD type 1   	SPD type 1   

FURTHER NORMATIVE MINIMUM REQUIREMENTS

Cross sections:

- Equipotential bonding conductors not carrying lightning current:
 - At least 6 mm² copper or equivalent.
- Equipotential bonding conductors carrying lightning current:
 - At least 16 mm² copper or equivalent.

Selection of U_c and U_p :

- $U_c > 1.2 \cdot U_{ocstc}$
- $U_p < (5 \cdot U_{ocstc}) \cdot 0.8$ or

$U_p < U_w \cdot 0.8$ (U_w : dielectric strength of equipment)

Derivative values in acc. with:

A) IEC 61643-32 and DIN VDE 0100-712

- **Type 1 surge protectors: min. Iimp: 12.5 kA/pole (10/350)**

Deviating Iimp for type 1 surge protectors can vary depending on the risk

- for DC arresters according to IEC 61643-32 appendix A,
- for AC arresters according to lightning protection class and lightning current distribution according to EN 61643-12

- **Type 2 surge protectors (AC and DC): min. 5 kA/pole (8/20)**

B) VDE 0185-305-3 Supplement 5:2014:

- **Type 1 surge protectors:**
 - for DC arresters according to section 5.3.2, tables 2 and 3: 2.5 kA/pole (10/350) to 25 kA/pole (10/350) depending on

the earthing concept, system design or system type and arrester technology

- for AC arresters close to:
 - Inverter: min. 12.5 kA/pole (10/350).
 - Feed-in point or lightning protection zone transition according to lightning protection class and lightning current distribution according to EN 61643-12, values up to 25 kA/pole (10/350).

- **Type 2 surge protectors (AC and DC): min. 5 kA/pole (8/20)**

Conclusion DC side:

If a DC type 1 arrester is required, an Iimp= 12.5kA/pole (10/350) is sufficient for almost all systems, regardless of the various standards. The DS60VG series thus offers the user a product that is conform to the standards, which also does not require complicated calculations in planning and can be used in almost every system. If smaller values are determined by a detailed calculation or when using Supplement 5, the DS50VGPVS-12KT1 series as type 1+2 surge protector with an Iimp= 6.25kA/pole (10/350) is the most cost- and space-optimized version. The DS50VGPVS-G/51 series is used here as a DC type 2 arrester.

Conclusion AC side:

On the AC side, the DS250VG series with 25kA/pole is available as type 1+2+3 arresters for highest loads and the DAC1-13VG or ZPAC series with 12.5kA/pole for average loads. The arresters of the DAC50VG series complete the AC side as type 2+3.





CABLE LENGTHS

If cable lengths of >10m are achieved on both the AC and DC side, 2 surge protection devices are required.

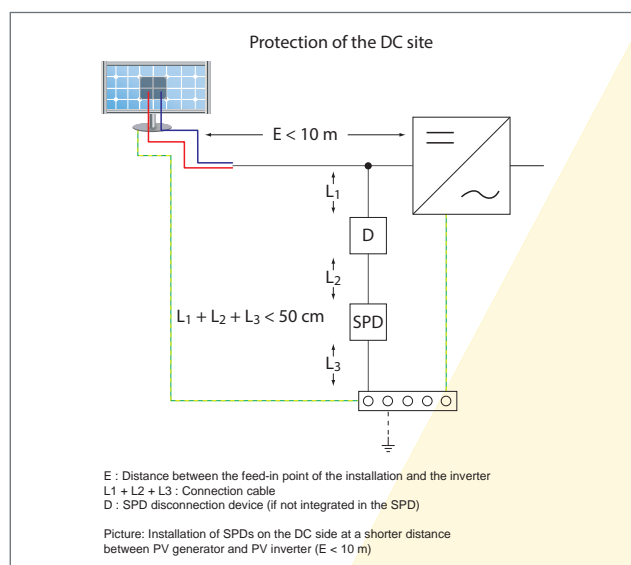
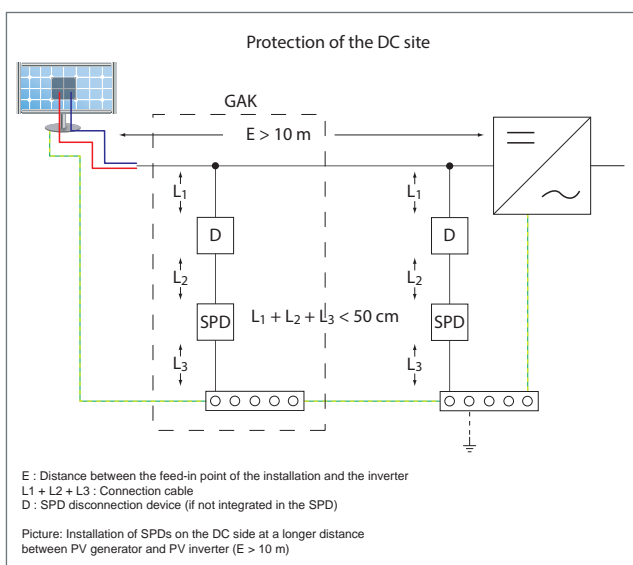
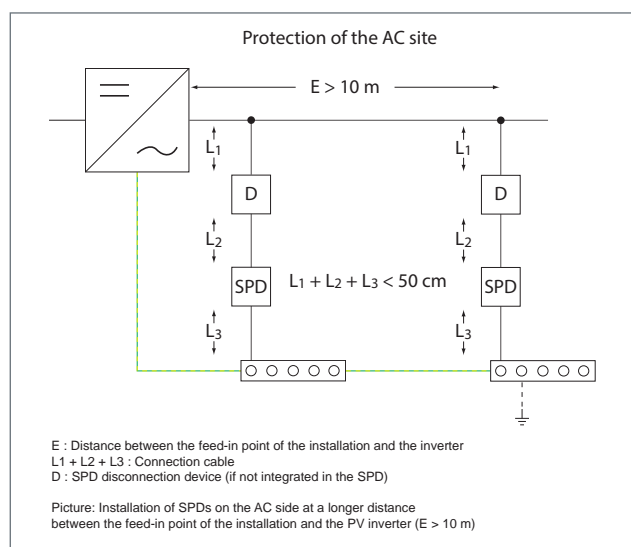
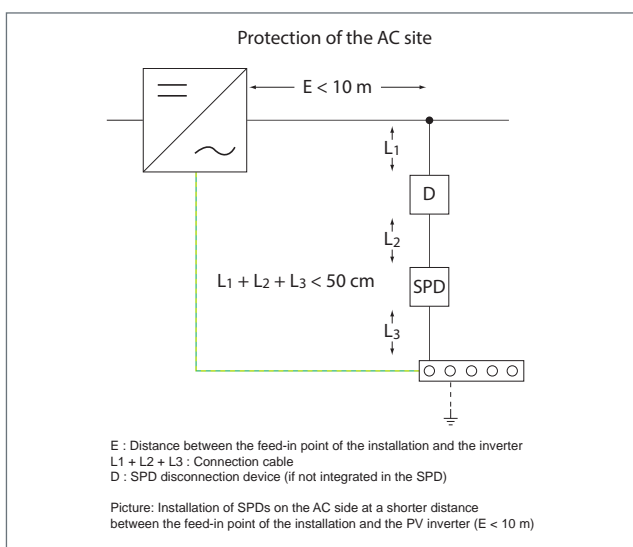

PRODUCT SELECTION (exemplary)

AC SURGE PROTECTORS (SPD)



A1 DS252VG-300

AC surge protector type 1+2+3 based on a gas-filled spark gap

- 10 years warranty
- Safe disconnecter
- Generates no (grid) follow current
- Free of operating and leakage current
- Fulfills the VDN guideline for use in the pre-meter area
- Remote signaling as standard
- Complies with standards IEC 61643-11 and EN 61643-11

Art. des.	DS252VG-300	DS253VG-300	DS254VG-300	DS-254VG-300/G
System type	TN (2+0)	TNC (3+0)	TNS (4+0)	TT (3+1), TNS
limp / pole	25 kA	25 kA	25 kA	25 kA
limp total	50 kA	75 kA	100 kA	100 kA
In / pole	30 kA	30 kA	30 kA	30 kA
Up	< 1.5 kV	< 1.5 kV	< 1.5 kV	< 1.5 kV
Ipe	none	none	none	none
If	none	none	none	none
Art. No.	3469	3896	3713	2756



A2 DAC1-13VGS-31-275

AC surge protector type 1+2+3 based on a gas-filled spark gap

- 10 years warranty
- Safe disconnecter
- Generates no (grid) follow current
- Free of operating and leakage current
- Fulfills the VDN guideline for use in the pre-meter area
- Pluggable protection modules
- Remote signaling as standard
- Complies with standards IEC 61643-11 and EN 61643-11

Art. des.	DAC1-13VGS-20-275	DAC1-13VGS-30-275	DAC1-13VGS-40-275	DAC1-13VGS-31-275
System type	TN (2+0)	TNC (3+0)	TNS (4+0)	TT (3+1), TNS
limp / pole	12.5 kA	12.5 kA	12.5 kA	12.5 kA
limp total	25 kA	37.5 kA	50 kA	50 kA
In / pole	20 kA	20 kA	20 kA	20 kA
Up	< 1.5 kV	< 1.5 kV	< 1.5 kV	< 1.5 kV
Ipe	none	none	none	none
If	none	none	none	none
Art. No.	821730222	821730223	821730224	821730244



A2 ZPAC1-13VG-31-275

AC surge protector type 1+2+3 based on a gas-filled spark gap

- 10 years warranty
- Safe disconnecter
- Generates no (grid) follow current
- Free of operating and leakage current
- Fulfills the VDN guideline for use in the pre-meter area
- Pluggable protection modules
- Remote signaling as standard
- Complies with standards IEC 61643-11 and EN 61643-11

Art. des.	ZPAC1-13VG-31-275	ZPAC1-8VG-31-275
System type	TT, TNS	TT, TNS
limp / pole	12.5 kA	8 kA
limp total	50 kA	32 kA
In / pole	20 kA	20 kA
Up	< 1.5 kV	< 1.5 kV
Ipe	none	none
If	none	none
Art. No.	64004	64006



A3 DAC50VGS-31-275

AC surge protector type 2+3 based on a gas-filled spark gap

- 10 years warranty
- Safe disconnecter
- Generates no (grid) follow current
- Free of operating and leakage current
- Pluggable protection modules
- Remote signaling as standard
- Complies with standards IEC 61643-11 and EN 61643-11

Art. des.	DAC50VGS-20-275	DAC50VGS-30-275	DAC50VGS-40-275	DAC50VGS-31-275
System type	TN (2+0)	TNC (3+0)	TNS (4+0)	TT (3+1), TNS
In / pole	20 kA	20 kA	20 kA	20 kA
I _{max} / pole	50 kA	50 kA	50 kA	50 kA
Up	< 1.5 kV	< 1.5 kV	< 1.5 kV	< 1.5 kV
Ipe	none	none	none	none
If	none	none	none	none
Art. No.	821130222	821130223	821130224	821130244



PRODUCT SELECTION (exemplary)

DC SURGE PROTECTORS (SPD)



B1 DS60VGPV-1000G/51

DC surge protector type 1+2 based on a gas-filled spark gap

- 10 years warranty
- Double safe disconnecter
- Galvanic isolation
- No aging due to operating and leakage currents
- Error-resistant, reverse polarity protected Y-circuit
- Remote signaling as standard
- Complies with standards IEC 61643-11, EN 61643-11 and EN 50539-11, UTE C 61-740-51

Art. des.	DS60VGPV-600G/51	DS60VG-PV-1000G/51	DS60VG-PV-1500G/51
Uocstc	600 Vdc	1000 Vdc	1250 Vdc
Ucpv	720 Vdc	1200 Vdc	1500 Vdc
Iimp / pole	12.5 kA	12.5 kA	12.5 kA
I _{max} / pole	40 kA	40 kA	40 kA
U _p (In)	< 1.7 kV	< 2.8 kV	< 3.4 kV
I _{pe}	none	none	none
I _f	none	none	none
Art. No.	3963	3958	3956



B1 DS50PVS-1000G/12KT1
DS50VGPVS-1000G/12KT1

DC surge protector type 1+2 based on a gas-filled spark gap

- Double safe disconnecter
- Galvanic isolation
- No aging due to operating currents (VG only)
- No aging due to leakage currents
- Error-resistant, reverse polarity protected Y-circuit
- Remote signaling as standard
- Especially suitable for buildings with >4 down conductors according to Table 2, VDE 0185-305-3 Supplement 5
- Complies with standard EN 50539-11

Art. des.	DS50VG-PVS-1000G/12KT1	DS50PVS-1000G/12KT1	DS50PVS-1500/12KT1
Uocstc	1000 Vdc	1000 Vdc	1250 Vdc
Ucpv	1200 Vdc	1200 Vdc	1500 Vdc
Iimp / pole	6.25 kA	6.25 kA	6.25 kA
I _{max} / pole	40 kA	40 kA	40 kA
U _p (In)	< 2.8 kV	< 2.6 kV	< 5.3 kV
I _{pe}	none	none	none
I _f	none	none	none
Art. No.	482313	482393	482573



for VG arrestors



B2 DS50VGPVS-1000G/51

DC SPD type 2 based on a gas-filled spark gap

- 10 years warranty
- Double safe disconnecter
- Galvanic isolation
- No aging due to operating and leakage currents
- Error-resistant, reverse polarity protected Y-circuit
- Pluggable protection modules
- Remote signaling as standard
- Complies with standards IEC 61643-11, EN 61643-11 and EN 50539-11, UTE C 61-740-51

Art. des.	DS50VG-PVS-600G/51	DS50VG-PVS-1000G/51	DS50VG-PVS-1500G/51
Uocstc	600 Vdc	1000 Vdc	1250 Vdc
Ucpv	720 Vdc	1200 Vdc	1500 Vdc
I _n / pole	15 kA	15 kA	15 kA
I _{max} / pole	40 kA	40 kA	40 kA
U _p (In)	< 1.8 kV	< 2.8 kV	< 3.4 kV
I _{pe}	none	none	none
I _f	none	none	none
Art. No.	481411	481311	481511



DDC40CS-20-275

SPD type 2 for DC applications

- Compact 2-pole DC surge arrester type 2
- Safe disconnecter
- Transverse / longitudinal voltage protection
- The smallest type 2 arrester available on the market
- Pluggable protection modules
- Remote signaling as standard
- Complies with standards IEC 61643-11 and EN 61643-11

Art. des.	DDC20CS-20-24	DDC40CS-20-100	DDC40CS-20-275	DDC40CS-20-460
Uc DC	24 Vdc	100 Vdc	275 Vdc	460 Vdc
I _n / pole	10 kA	20 kA	20 kA	20 kA
I _{max} / pole	20 kA	40 kA	40 kA	40 kA
U _p	< 250 V	< 390 V	< 900 V	< 1400 V
I _{pe}	< 0.1 mA	< 0.1 mA	< 0.1 mA	< 0.1 mA
I _f	none	none	none	none
Art. No.	on request	on request	on request	on request



PRODUCT SELECTION (exemplary)

SPD SYSTEMS FOR PHOTOVOLTAIC SYSTEMS



C1 CiPlug1

String combiner box (SCB) CiPlug1 with 1 string

- SCB for 1 MPP tracker
- Integrated surge protection
- IP 65, SK II and IK 8 housing
- Housing material: UV and ozone resistant, glass fiber reinforced polycarbonate with pressure compensation element
- Premassembled connection cables with MC4-plugs
- Other solutions available on request



Article designation		CiPlug1
Nominal voltage	Un	1000 Vdc
Rated insulation voltage	Ui	1000 Vdc
Rated current	InA	20 A
Rated phase current	InC	20 A
Input / per MPPT		MC4 plug 1x6mm ²
Output / per MPPT		MC4 plug 1x6mm ²
Earth connection terminal		Screw terminal 2.5-25 mm ² [35 mm ²]
Dimensions		WxHxD (mm): 110 x 180 x 84
DC disconnection		none
Fuse holder		none
Surge protection device		DS60 or DS50 series
Surge protection type		Surge protector type 1+2 or SPD type 2
Technology		Diverse
Complies with standard		DIN EN 50539-11
Article number		on request



C1 GAK1.K6x16.K2x16.51VG-1



Article designation		GAK1.K6x16.K2x16.51VG-1
Nominal voltage	Un	1000 Vdc
Rated insulation voltage	Ui	1000 Vdc
Rated current	InA	30 A
Rated phase current	InC	15 A
Input / per MPPT		Spring-cage terminals 4x 16mm ²
Output / per MPPT		Spring-cage terminals 2x 16mm ²
Earth connection terminal		Spring-cage terminals 1x 16mm ²
Dimensions		WxHxD (mm): 254 x 180 x 111
DC disconnection		none
Fuse holder		none
Surge protection device		DS50VGPVS-1000G/51
Surge protection type		Arrester type 2
Technology		VG Technology
Complies with standard		DIN EN 50539-11
Article number		158107

String combiner box (SCB) with 4 strings

- SCB for 1 MPP tracker
- Integrated surge protection
- IP 65, SK II and IK 8 housing
- Housing material: UV and ozone resistant, glass fiber reinforced polycarbonate with pressure compensation element
- Other solutions available on request



C1 GAK1.K6x16.K2x16.S.51VG-1



Article designation		GAK1.K6x16.K2x16.S.51VG-1
Nominal voltage	Un	1000 Vdc
Rated insulation voltage	Ui	1000 Vdc
Rated current	InA	30 A
Rated phase current	InC	15 A
Input / per MPPT		Screw terminals 4x 16mm ²
Output / per MPPT		Spring-cage terminals 2x 16mm ²
Earth connection terminal		Spring-cage terminals 2x 16mm ²
Dimensions		WxHxD (mm): 360 x 254 x 111
DC disconnection		none
Fuse holder		4x 10x38mm in plus and minus pole
Surge protection device		DS50VGPVS-1000G/51
Surge protection type		Arrester type 2
Technology		VG Technology
Complies with standard		DIN EN 50539-11
Article number		158407

String combiner box (SCB) with 4 strings

- SCB for 1 MPP tracker
- Integrated surge protection
- Protection against reverse currents by PV fuses
- IP 65, SK II and IK 8 housing
- Housing material: UV and ozone resistant, glass fiber reinforced polycarbonate with pressure compensation element
- Other solutions available on request

PRODUCT SELECTION (exemplary)

SPD SYSTEMS FOR PHOTOVOLTAIC SYSTEMS



String combiner box (SCB) with 1 string

- SCB for 1 MPP tracker
- Integrated surge protection
- IP 65, SK II and IK 8 housing
- Housing material: UV and ozone resistant, glass fiber reinforced polycarbonate with pressure compensation element
- Other solutions available on request



GAK1.K1x120.K1x120.61-1



Article designation		GAK1.K1x120.K1x120.61-1
Nominal voltage	Un	1000 Vdc
Rated insulation voltage	Ui	1000 Vdc
Rated current	InA	200 A
Rated phase current	InC	150 A
Input / per MPPT		Screw terminals 1x up to 150mm ²
Output / per MPPT		Screw terminals 1x up to 150mm ²
Earth connection terminal		Spring-cage terminals 1x 16mm ²
Dimensions		WxHxD (mm): 400 x 600 x 132
DC disconnection		none
Fuse holder		none
Surge protection device		DS60VGPV-1000G/51
Surge protection type		Surge protector type 1+2
Technology		VG Technology
Complies with standard		DIN EN 50539-11
Article number		158600



DLA-06D3



DLA-12IS

SPD for RS422 / RS485

- Only 13mm (DLA) or 18mm (DLA-IS)
- For all MSR, telecommunications and data technology applications
- Protected shield connection
- Pluggable protection module
- Earthing via DIN rail
- Complies with standard IEC 61643-21
- Other solutions available on request

Art. des.	DLA-06D3	DLA-12D3	DLA-24D3	DLA-48D3	DLA-12-IS
Appl.	RS422 / RS485	RS232	Current loop 4-20 mA	ISDN-TO 48 V	RS485 RS232
Config.	2 wires + shield	2 wires + shield	2 wires + shield	2 wires + shield	2 wires + shield + signal ground
Un	6 V	12 V	24 V	48 V	12 V
UC AC / DC	8 V / 6 V	15 V / 10 V	28 V / 20 V	53 V / 37 V	15 V / 10 V
Up	< 20 V	< 30 V	< 40 V	< 70 V	< 30 V
Iimp	5 kA	5 kA	5 kA	5 kA	5 kA
I _{max}	20 kA	20 kA	20 kA	20 kA	20 kA
Art. No.	6401011	6402011	6403011	6403021	640152



Surge arrester for Ethernet, POE, data and telecommunications technology

- High quality shielded housing with two RJ45 sockets
- 2-stage protection circuit
- Shielded
- Optimum protection level for network applications
- Easy installation
- Complies with standard IEC 61643-21



MJ8-CAT6S

Art. des.	MJ8-CAT6S	MJ8-POE-A	MJ8-POE-B	MJ8-170V
Application	Ethernet 100/1000 Base T	Power over Ethernet	Power over Ethernet	DSL
Connection	RJ45	RJ45	RJ45	RJ45
UC	8 V PIN (1-2) (3-6) (4-5) (7-8)	60 V PIN (1-2) (3-6) (4-5) (7-8)	7.5 V PIN (1-2) (3-6) 60 V PIN (4-5) (7-8)	170 V PIN (1-2) (3-6) (4-5) (7-8)
Up	< 20 V	< 70 V	< 70 V	< 220 V
In	2 kA	2 kA	2 kA	2 kA
Art. No.	560303	581519	581518	560203



CITEL

Head Office France CITEL-2CP

2, rue Troyon
92316 Sèvres CEDEX
France
Phone: +33 1 41 23 50 23
Fax: +33 1 41 23 50 09
e-mail: contact@citel.fr
Web: www.citel.fr

Production France CITEL-2CP

3 impasse de la Blanchisserie
BP 56
51052 Reims CEDEX
France
Phone: +33 3 26 85 74 00
e-mail: contact@citel.fr

Germany CITEL Electronics GmbH

Alleestrasse 144, Tor 5
D-44793 Bochum
Germany
Phone: +49 234 54 72 10
Fax: +49 234 54 72 199
e-mail: info@citel.com
Web: www.citel.de

USA CITEL Inc.

10108 USA Today Way
Miramar, FL33025
USA
Phone: (954) 430 6310
Fax: (954) 430 7785
e-mail: info@citel.us
Web: www.citel.us

China Shanghai CITEL Electronics Co, Ltd

Sales department:
Room 509, Building 1, n°88,
Shangke Road,
201315 Pudong, Shanghai
P.R. CHINA
Phone: +86 21 58 12 25 25
Fax: +86 21 58 12 21 21
e-mail: info@citelsh.com
Web: www.citel.cn

Production:
499 Kang Yi Road
Kang Qiao Industrial Zone
201315 Pudong, Shanghai
P.R. CHINA
Phone: +86 21 58 12 80 67

Russia CITEL Vostok

Yakovoapostolskiy pereulok 11/13,
building 4, office 4.
105064 Moscow
Russia
Phone: +74993914764
e-mail: info@citel.ru
Web: www.citel.ru

India CITEL India

305, DLF Courtyard
Plot No. A - 4, Saket District Centre
Package, New Delhi - 110017
India
Phone: +91 11 400 18131
e-mail: indiacitel@gmail.com
Web: www.citel.in

Thailand CITEL Thailand

Exchange Tower, level 29,
Unit 2901-2904,
388 Sukhumvit Road, Klongtoey
Klongtoey, Bangkok 10110
Thailand
Phone: +66 (0) 2 104 9214
Web: www.citel.fr

