

Applicable to T7 / T10 / T14 / T17/ T21

Parallel Scheme of Tower



Important:

The parallel connection of the Tower series and all other related work are only allowed by professional and qualified electricians.

This scheme is a brief instruction for Tower parallel connection, and cannot replace the original user manual.

The total voltage difference between clusters is less than 10V; SOC of each cluster should be 100% and time interval between newly added cluster and existing cluster should be less than 6 months.

Maximum 4 tower clusters are allowed to be connected in parallel.

1 Parallel scheme introduction

In order to meet the market demands, Dyness has developed parallel function for Tower series. This parallel scheme is applicable to all tower models.

2 Main Equipment required



BDU-2G + Battery module + base

Combiner box
DCB-TW

3 Parallel wiring

The general configuration diagram of the Towers in parallel connection is as under:

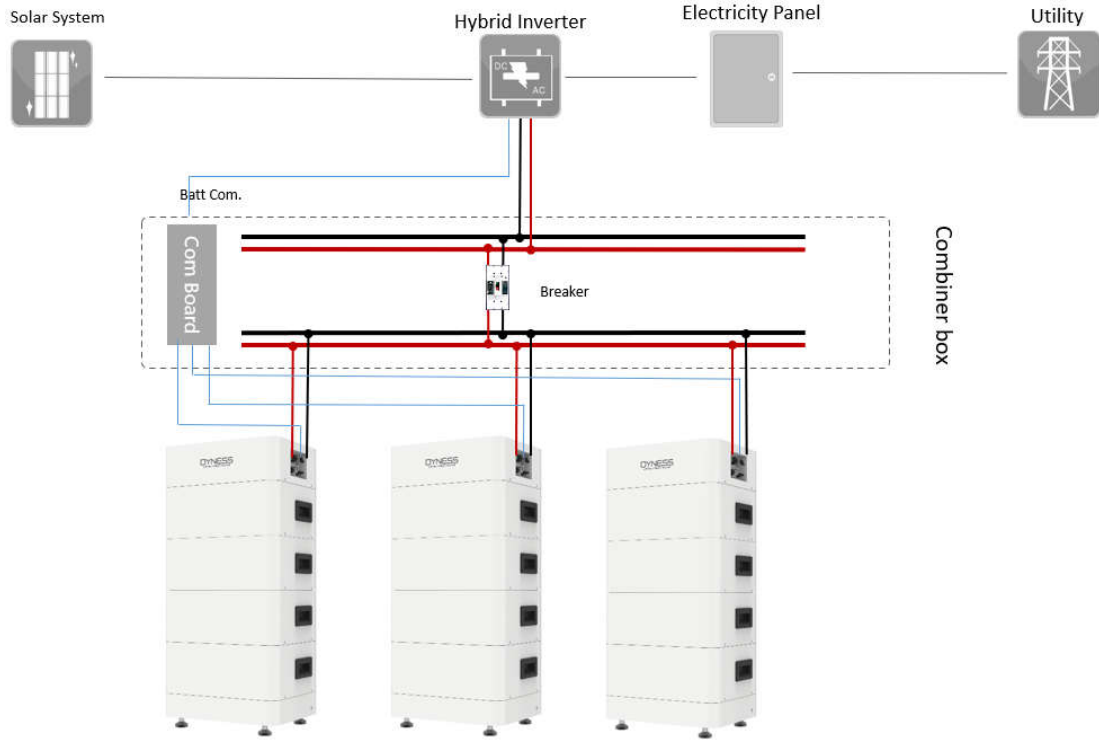
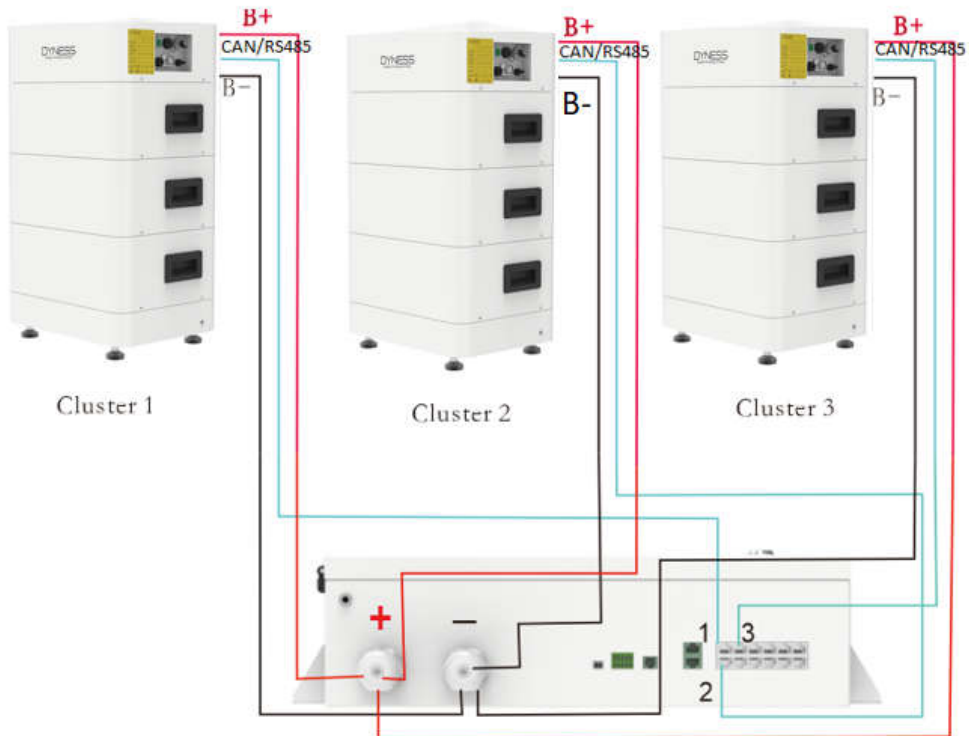

Figure 3-1 The general configuration diagram of the Towers

Connection between Towers and combiner box



Connection diagram between tower and combiner box

Figure 3-2 Tower and Combiner Box connection diagram

Power line connection:

Standard power lines are connected from the BDU-2G to the DC circuit breaker inside the Combiner box (DCB-TW) through the Gland head.



Figure 3-3

Communication network cable connection: standard network cable

Communication network cables are connected from communication port of the BDU-2G of tower 1, 2, 3 and 4 to the communication hub port 1,2,3, 4 of the combiner box. Please note don't connect other ports of communication hub.

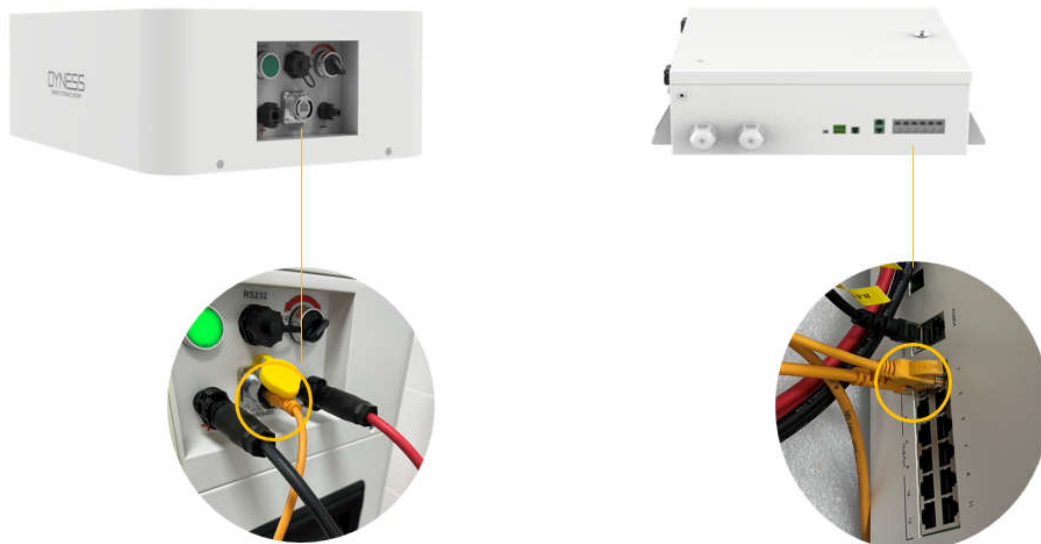

Figure 3-4

Connection between inverter and combiner box

Power line connection:

Below is the illustration of power cables laying out from the combiner box. A power cable is connected from power supply port of combiner box to external AC power. And the power lines go through the grand head to the inverter. The connection at inverter side is subject to the ports of specific inverter.

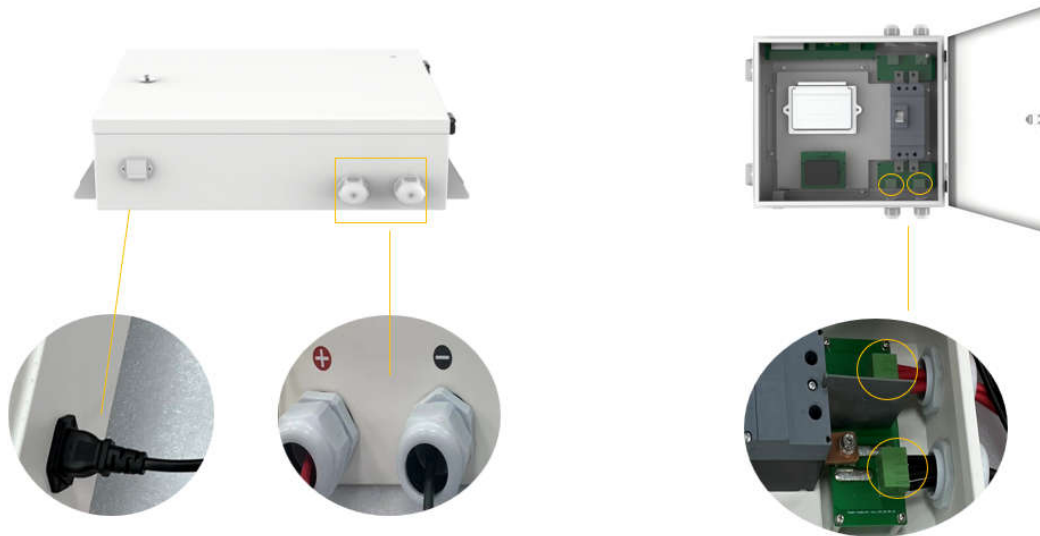

Figure 3-5

Communication network cable connection: standard network cable

Communication network cable is connected from communication port CAN or RS485 of the combiner box to the communication port of the inverter. whether using CAN or RS485 depends on the communication mode of inverter



Figure 3-6

Set DIP switch



If the number of towers in parallel is more than two, please open BDU of tower, and make DIP switch setting as shown in the figure for each tower. Otherwise, there is no need to set DIP switch.

4 Compatible list of inverters

Please refer to Dyness compatible list. Please contact Dyness for details if needed.

5 Attention

- DCB-TW is IP20. Client has to use the combiner box indoors
- The label on BDU box is yellow, and the label on packing box is named as BDU-2G.
- The Towers in parallel must be of the same model and same capacity.
- The time interval between the newly added modules and the existing modules in single Tower is not more than 6 months. During capacity expansion, make sure SOC of each module is 100%.



Power You Day and Night



Official Website



Digital version access

Address: No. 511 Chenzhuang West Road, Sanshui Street, Jiangyan District,
Taizhou City

Email: service@dyness-tech.com

Tel: +86 400 666 0655

Web: www.dyness-tech.com
